

## EQUIPMENT

# DF 3500

- High separation efficiency
- Very low pressure drop leading to lower operating costs
- Corrosion resistant
- Simple installation
- Low maintenance cost due to simple operating principle and long lifetime
- Wide face velocity range
- Tailor made sizes and designs
- Hygienic design
- Wide range of highest quality material
- In house ISO 9001 certified manufacturing

# DF 3500

## Droplet Separator



DF 3500 is a ready-to-install droplet separator for use as air intakes in marine and offshore applications. It is available in various material combinations and configurations to fit a wide range of operating conditions.

DF 3500 droplet separator provides high efficiency droplet separation and low pressure drop even at high face velocity. The droplet separator can be configured to most individual performance and installation situations, providing a cost effective solution. Alternative material choices and drainage systems, as well as add-on features like flanges and protection mesh are just some of the configuration options.

DF 3500 droplet separator is an excellent choice air intakes in marine and offshore applications. It is best suited for keeping splashwater, sea spray, mist and larger fog water droplets out of a ventilation system. Whenever the natural operating conditions are very harsh, the DF 3500 provides excellent protection from water. This helps to reduce corrosion, to increase filter lifetime and to reduce moisture throughout the system. The unit is suitable for use at face velocities of up to 6 m/s.

### Separation technology

The streamlined separator deflects the droplet laden gas stream, as a result the momentum of the droplets causes them to impinge onto the profile surface. The droplets coalesce together and form a liquid film, the influence of gravity causes the liquid to drain to the bottom of the profiles. Specially shaped separation chambers improve performance by enhancing the separation of finer droplets and ensuring problem free discharge of liquid.

To avoid “flooding” of the profiles and the possibility of re-entrainment of the separated liquid, the height of the profile sections, droplet separator is normally limited to 2,500 mm.

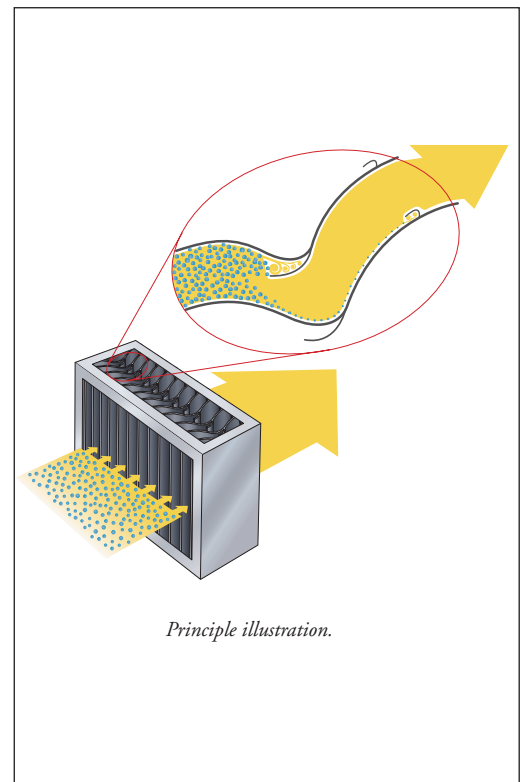

*Principle illustration.*

## Performance

The limit drop size represents a performance characteristic of the profile, at the relevant velocity and operating conditions it is the size of the smallest droplet that is completely separated. The diagram showing limit drop size has been calculated for an air/water system at 20 °C and 1 bar.

The pressure drop is measured at ambient conditions (20 °C and 1 bar) through a number of assembled profiles and under ideal conditions.

## Liquid load

Maximum liquid load; 250 gram water/kg air, measured under ideal conditions at 20 °C, 1 bar and a face velocity of 4.5 m/s with a pitch/spacing of 25 mm between the profiles.

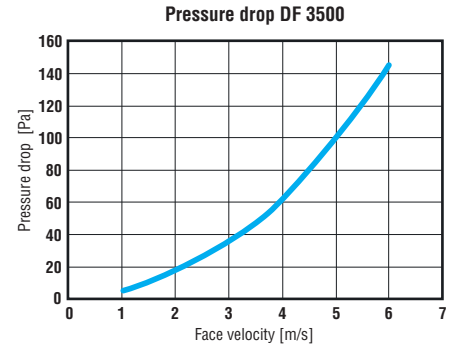
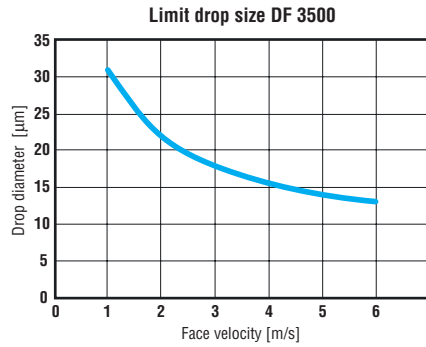

— 25 mm pitch/spacing between profiles

*For any data outside the specified range, please contact your nearest Munters representative.*

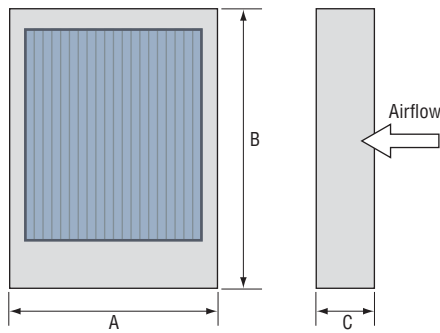

## Type, material and dimension specifications

Type code	Material		Pitch/spacing between profiles mm	Width*** A mm min-max	Height*** B mm min-max	Depth C mm	Operating temp °C min-max
	Frame**	Profile					
2b	316L	PPTVb****	25	300-2,500	300-2,500	165	+5 - +100
3b	316Ti	PPTVb****	25	300-2,500	300-2,500	165	+5 - +100
4b	AlMg3*	PPTVb****	25	300-2,500	300-2,500	165	+5 - +100
8a	AlMg3*	AlMgSi0.5	25	300-2,500	300-2,500	165	+5 - +100

PPTV = Talcum reinforced polypropylene (b = black)  
 316L = Stainless steel (AISI 316L, DIN 1.4404)  
 316Ti = Stainless steel (AISI 316Ti, DIN 1.4571)  
 AlMg3 = Aluminium alloy  
 AlMgSi0.5 = Aluminium alloy

\* Anodised or coloured material on request.

\*\* All frames can be painted on request (specify RAL code).

All frames powder coated on request.

Aluminium frames of other aluminium alloys on request.

All frames can be brushed to give a frosted appearance, stainless steel can be obtained polished.

\*\*\* Standard tolerance on width and height: +0, -5 mm.

\*\*\*\* Special polypropylene compound for min temperature -40 °C on request.

## Drainage positions

Code for drainage position, put P before the position number, e.g., P9 or P6,8,9,10 if more outlets are to be used.

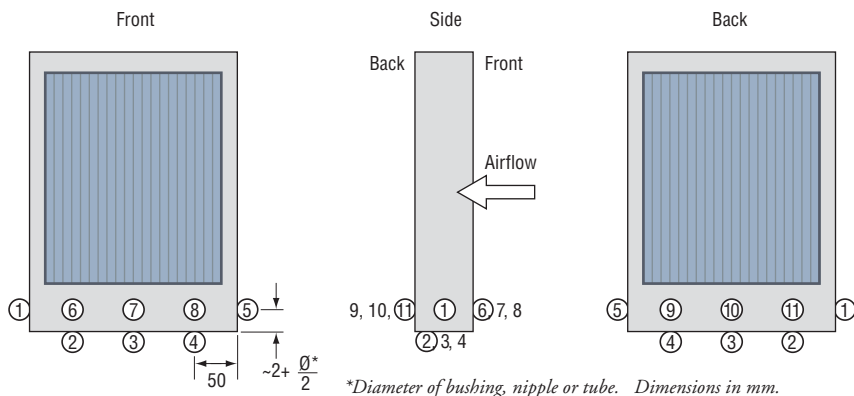

\*Diameter of bushing, nipple or tube. Dimensions in mm.

⑫ Slot throughout the entire bottom for use with separate housing/tray.

*Drawing for fittings (see next page).*

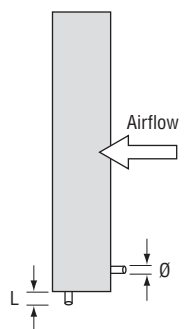

# Fittings specifications

## For aluminium frames

### Tubes

Fitting code	Ø mm	L mm
A1	16	50
A2	20	50
A3	30	50
A4	42	50
A5	54	75
A6	65	75
A7	76	75

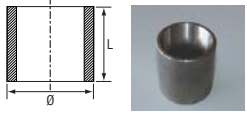

Fitting material AlMgSi0.5 aluminium alloy.

## For stainless steel frames

### Bushing

Inside threads, both sides.

Fitting code	Ø inch	L mm
B1	1/2	34
B2	3/4	36
B3	1	43
B4	1 1/2	48
B5	2	56
B6	2 1/2	70
B7	3	95

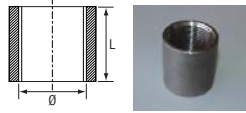

### Half bushing

Inside threads, both sides.

Fitting code	Ø inch	L mm
C1	1/2	15
C2	3/4	17
C3	1	19
C4	1 1/2	22
C5	2	26

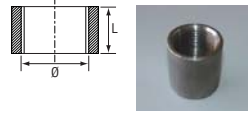

### Weld-on nipple

External threads, one side.

Fitting code	Ø inch	L mm
D1	1/2	35
D2	3/4	40
D3	1	40
D4	1 1/2	50
D5	2	50
D6	2 1/2	60
D7	3	65

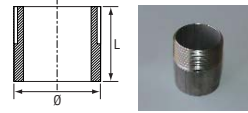

### Nipple\*

External threads, entire length.

Fitting code	Ø inch	L mm
E1	1/2	25
E2	3/4	40
E3	1	35
E4	1 1/2	38
E5	2	45

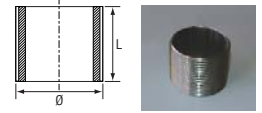

Bushing according to DIN 2986, nipples DIN 2982, material 316Ti (AISI 316Ti, DIN 1.4571), witworth – thread according to DIN 259. \* In combination with bushing (fitting code B).

N.B. The required cross-section of the water outflow depends on both application and liquid load. Most frequently used fitting sizes are 3/4" and 1" and corresponding tube sizes.

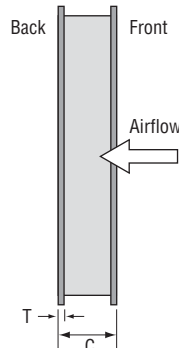
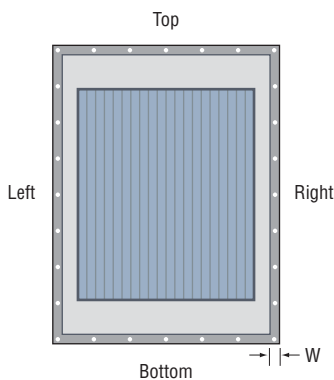

Hole configurations in flanges are delivered according to Eurovent, DIN 24193, Norsok or other trade, national or international standards (specify standard). Hole configuration according to individual requirements are also delivered (specify drill pattern and hole diameter, provide drawing or use sketch on last page).

N.B. Depths [C] is the same with or without flanges.

Code	[mm] min-max
R	50-500



Code for radius, put R before the dimension, e.g. R150

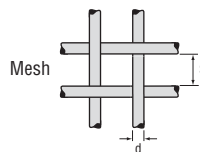
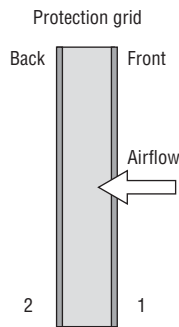

## Flanges specifications

Flange code		Position	Thickness*, T	
Continuous welded	Spot welded		code	mm
F1	F11	Top & bottom front	T2	2
F2	F12	Left & right front	T3	3
F3	F13	All sides front	T5	5
F4	F14	Top & bottom back	T8	8
F5	F15	Left & right back	Width*, W	
F6	F16	All sides back	code	mm
F7	F17	Top & bottom, front & back	W30	30
F8	F18	Left & right, front & back	W50	50
F9	F19	All sides front & back	W60	60

Material: Aluminium and stainless steel in accordance with the frame material selected. \* Other thickness or width on request.

## Protection grid and mesh type specifications

Protection grid code	Position	Mesh width, S		Mesh type, wire diameter, d Ø [mm]			
		inch	mm	1.0	1.2	1.5	2.0
G1	Front	1/4 x 1/4	5 x 5	Q1			
G2	Back	1/4 x 1/4	6 x 6	Q2	X2		
		1/3 x 1/3	8 x 8	Q3	X3		
		1/2 x 1/2	10 x 10	Q4	X4		
		1/2 x 1/2	12 x 12	Q5		Y5	
		3/4 x 3/4	16 x 16	Q6	X6	Y6	
		3/4 x 3/4	20 x 20	Q7		Y7	Z7
		1 x 1	25 x 25			Y8	Z8

Material: Stainless steel 304 (AISI 304, DIN 1.4301). N.B. Protection grid is mainly used as trash screen on air inlets. Pressure drop over wire mesh is negligible.

## DF 3500

DF 3500 droplet separator is developed to suit a wide range of applications. The various outfit options cover the most typically occurring installation variations. However, tailor made droplet separators are frequently delivered based on customers' individual specifications.

Material certificates can be delivered for most materials upon request. Fractional efficiency curves for given face velocities are delivered on special request.

For hygienic-proof HVAC equipment DF 3500 droplet separator can be delivered in accordance with the standards VDI 6022, VDI 3803, DIN 1946 (specify H in order code).

## Order information

DF 3500-X-X-X-X-X-X-X-X-X-X-X-X

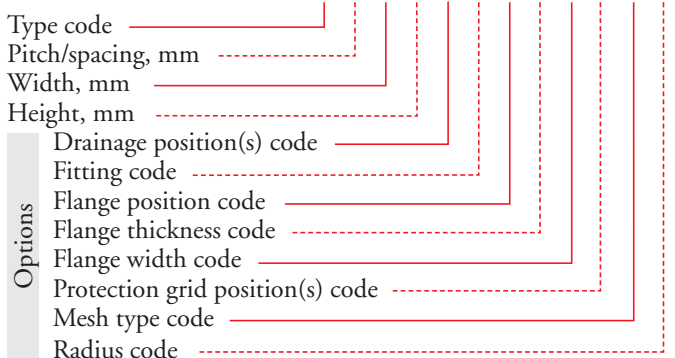

e.g., DF 3500-2b-25-1820-1200-P9-B5-F2-T2-W30-G2-Q4-R150

## Examples of installation

1. The droplet separator is flanged onto a wall opening and the water drains vertically outside of the wall.
2. The droplet separator is flanged into a wall opening and the water drains controlled into an internal tray (not shown in the drawing)
3. The droplet separator is installed in an air duct and stands in between angled profiles that are connected to the air duct. The water drains through the bottom into a tray that is below the air duct.

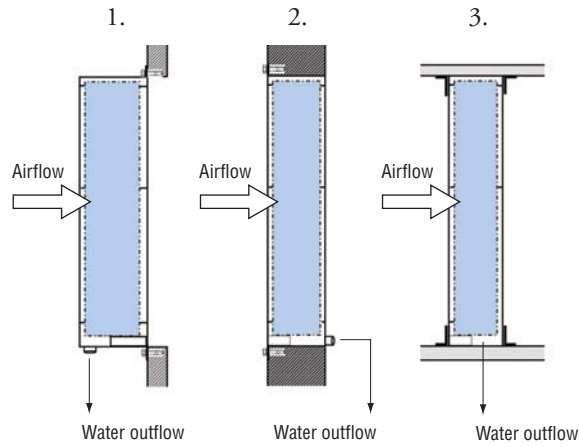

## Drill pattern sketch

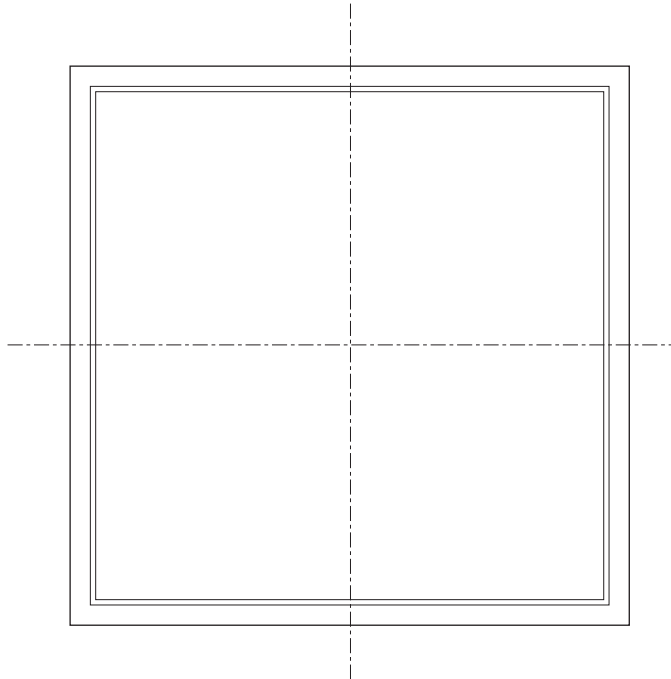

Munters Europe AB, HumiCool Division, Kung Hans Väg 8, P O Box 434, SE-191 24 Sollentuna, Sweden. Phone +46/(0)8/626 63 00, Fax +46/(0)8/754 56 66.  
Munters Euroform GmbH, Philipsstr.8, 52068 Aachen, P O Box 101109, 52011 Aachen, Germany. Phone +49/(0)241/89 00 0, Fax +49/(0)241/89 00 5199.

[www.munters.com](http://www.munters.com)

Austria via sales organization in Germany Munters Euroform GmbH, Phone +49/(0)241/89 00 0, Fax +49/(0)241/89 00 5199 Denmark via sales organization in Sweden Munters Europe AB, Phone +46/(0)8/626 63 00, Fax +46/(0)8/754 56 66,  
Finland Munters Oy, Phone +358/(0)9/83 86 0330, Fax +358/(0)9/83 86 0336, France Munters France S.A., Phone +33/(0)1/34 11 57 50, Fax +33/(0)1/34 11 57 51, Germany Munters Euroform GmbH, Phone +49/(0)241/89 00 0,  
Fax +49/(0)241/89 00 199, Italy Munters S.R.L., Phone +39/(0)2/488 6781, Fax +39/(0)2/488 1171, Munters euroemme S.p.A., Phone +39/(0)183/52 11, Fax +39/(0)183/521 333,  
Kingdom of Saudi Arabia and Middle East Hawa Munters, c/o Hawa United Cooling Syst. Co. Ltd., Phone +966/(0)1/477 15 14, Fax +966/(0)1/476 09 36, Norway via sales organization in Sweden, Munters Europe AB,  
Phone +46/(0)8/626 63 00, Fax +46/(0)8/754 56 66, South Africa & Sub-Sahara Countries Munters (Pty) Ltd, Phone +27/(0)11/455 2550/1/2, Fax +27/(0)11/455 2553, Spain Munters Spain S.A., Phone +34/91/640 09 02,  
Fax +34/91/640 11 32, Sweden Munters Europe AB, Phone +46/(0)8/626 63 00, Fax +46/(0)8/754 56 66, Switzerland via sales organization in Germany, Munters Euroform GmbH, Phone +49/(0)241/89 00 0, Fax +49/(0)241/89 00 199,  
United Kingdom Munters Ltd, Phone +44/(0)1480/442 340, Fax +44/(0)1480/411 332, Export & Other countries Munters Europe AB Phone +46/(0)8/626 63 00, Fax +46/(0)8/754 56 66,  
Region Americas Munters Corporation, Phone +1/(0)978 241 1100, Fax +1/(0)978 241 1214, Region Asia Munters K.K., Phone +81/(0)3/5970 0021, Fax +81/(0)3/5970 3197

Munters reserves the right to make alterations to specifications, quantities, etc., for production or other reasons, subsequent to publication.

© Munters Europe AB, 2003