

EQUIPMENT

DF 4800

- High separation efficiency
- Very thin design (97 mm)
- Very low pressure drop leading to lower operating costs
- Corrosion resistant
- Very easy installation
- Low maintenance cost due to simple operating principle and long lifetime
- Wide face velocity range
- Tailor made sizes and designs
- Hygienic design
- Wide range of highest quality material
- In house ISO 9001 certified manufacturing

DF 4800

Droplet Separator



DF 4800 is a ready-to-install droplet separator for use in many application areas. It is available in stainless steel and aluminium combinations and configurations to fit a wide range of operating conditions.

DF 4800 droplet separator provides high efficiency droplet separation and extreme low pressure drop even at medium face velocities giving energy saving operation.

The droplet separator can be configured to most individual performance and installation situations, providing a cost effective solution. Alternative material choices and drainage systems, as well as add-on features like flanges and protection mesh are just some of the configuration options.

DF 4800 droplet separator is an excellent choice for keeping rain, mist and larger fog water droplets out of a building or marine ventilation system. This helps to reduce corrosion, to increase filter lifetime and to reduce moisture throughout the system.

DF 4800 droplet separator is designed for use in many applications and for an easy integration into the superstructure. The unit is suitable for use at face velocities in between 1 to 7 m/s.

Separation technology

The streamlined separator deflects the droplet laden gas stream; as a result the momentum of the droplets causes them to impinge onto the profile surface. The droplets coalesce together and form a liquid film; the influence of gravity causes the liquid to drain to the bottom of the profiles. Specially shaped separation chambers improve performance by enhancing the separation of finer droplets and ensuring problem free discharge of liquid.

To avoid “flooding” of the profiles and the possibility of re-entrainment of the separated liquid, the height of the profile sections, droplet separators is normally limited to 2,500 mm.

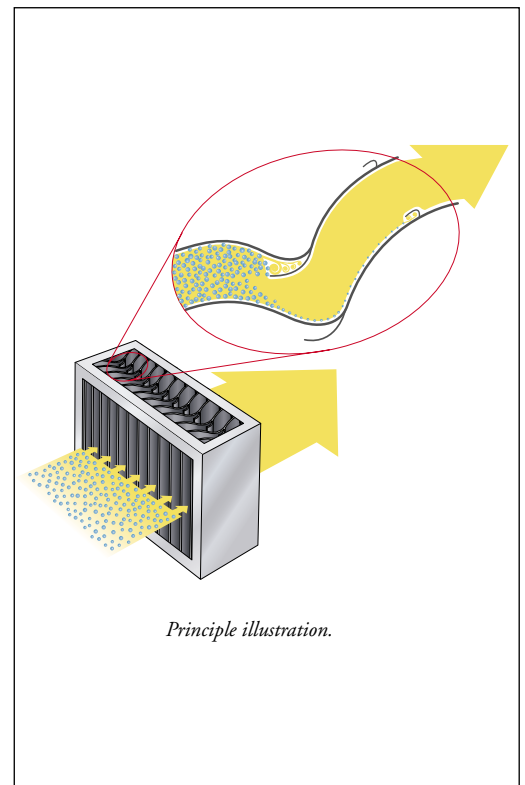

Performance

The limit drop size represents a performance characteristic of the profile, at the relevant velocity and operating conditions it is the size of the smallest droplet that is completely separated. The diagram showing limit drop size has been calculated for an air/water system at 20 °C and 1 bar.

The pressure drop is measured at ambient conditions (20 °C and 1 bar) through a number of assembled profiles under ideal conditions.

The fractional efficiency indicates the percentage of droplets, removed from an airstream, that are smaller than the limit drop size.

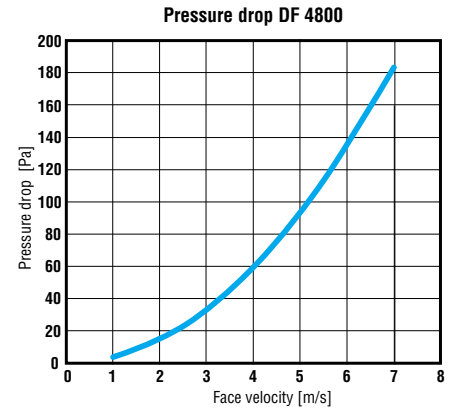
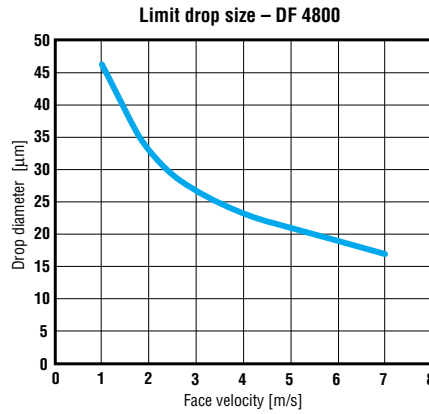

For any data outside the specified range, please contact your nearest Munters representative.

Liquid load

Maximum liquid load is fully sufficient for removing rain and spray completely under even harsh weather conditions.

Type, material and dimension specifications

Type code	Material		Width*** A mm min-max	Height*** B mm min-max	Depth C mm	Operating temp °C min-max
	Frame**	Profile				
8a	AlMg3*	AlMgSi0.5*	300-2,500	300-2,500	97	-
9m	304	304	300-2,500	300-2,500	97	-
9l	316L	316L	300-2,500	300-2,500	97	-
9s	316Ti	316Ti	300-2,500	300-2,500	97	-

AlMg3 = Aluminium alloy

AlMgSi0.5 = Aluminium alloy

304 = Stainless steel (AISI 304, DIN 1.4301)

316L = Stainless steel (AISI 316L, DIN 1.4404)

316Ti = Stainless steel (AISI 316Ti, DIN 1.4571)

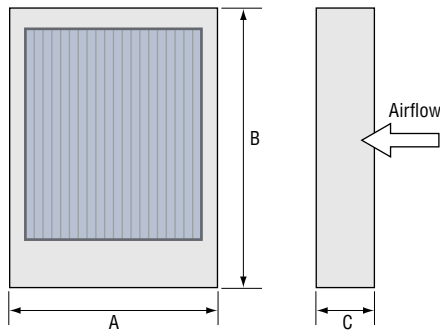

- * Anodised or coloured material on request.
- ** All frames can be painted on request (specify RAL code).
All frames powder coated on request.
Aluminium frames of other aluminium alloys on request.
All frames can be brushed to give a frosted appearance, stainless steel can be obtained polished.
- *** Standard tolerance on width and height: +0, -5 mm.
Materials specified are standard - other materials on request).

Drainage positions

Code for drainage position, put P before the position number, e.g., P9 or P6,8,9,10 if more outlets are to be used.

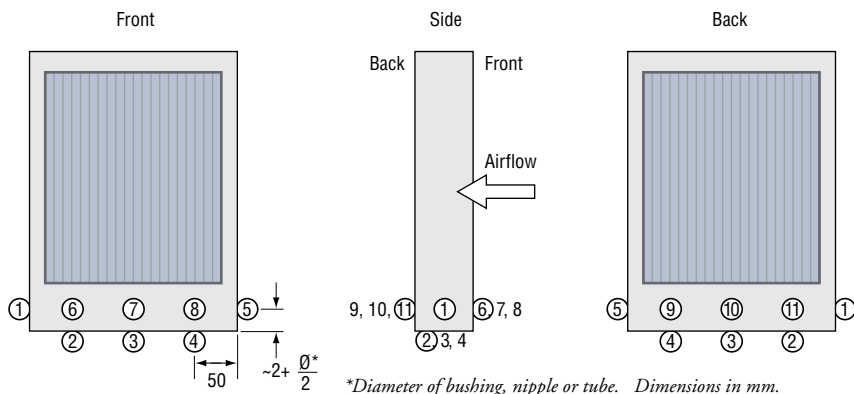

Drawing for fittings (see next page).

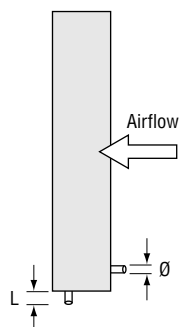

12 Slot throughout the entire bottom for use with separate housing/tray.

Fittings specifications

For aluminium frames

Tubes

Fitting code	Ø mm	L mm
A1	16	50
A2	20	50
A3	30	50
A4	42	50
A5	54	75
A6	65	75
A7	76	75

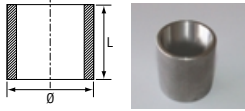

Fitting material AlMgSi0.5 aluminium alloy.

For stainless steel frames

Bushing Inside threads, both sides.

Fitting code	Ø inch	L mm
B1	1/2	34
B2	3/4	36
B3	1	43
B4	1 1/2	48
B5	2	56
B6	2 1/2	70
B7	3	95

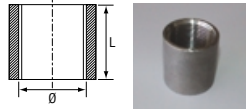

Bushing according to DIN 2986, nipples DIN 2982, material 316Ti (AISI 316Ti, DIN 1.4571), witworth – thread according to DIN 259. * In combination with bushing (fitting code B).

Half bushing Inside threads, both sides.

Fitting code	Ø inch	L mm
C1	1/2	15
C2	3/4	17
C3	1	19
C4	1 1/2	22
C5	2	26

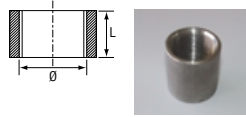

Weld-on nipple External threads, one side.

Fitting code	Ø inch	L mm
D1	1/2	35
D2	3/4	40
D3	1	40
D4	1 1/2	50
D5	2	50
D6	2 1/2	60
D7	3	65

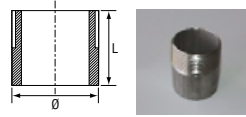

Nipple* External threads, entire length.

Fitting code	Ø inch	L mm
E1	1/2	25
E2	3/4	40
E3	1	35
E4	1 1/2	38
E5	2	45

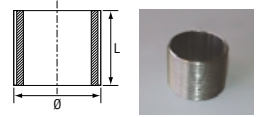

N.B. The required cross-section of the water outflow depends on both application and liquid load. Most frequently used fitting sizes are 3/4" and 1" and corresponding tube sizes.

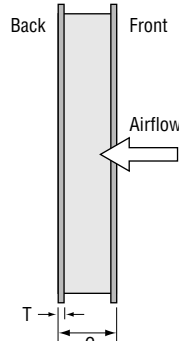
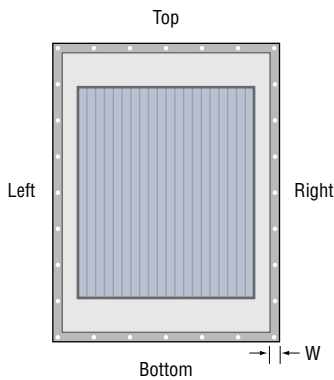

Hole configurations in flanges are delivered according to Eurovent, DIN 24193, Norsok or other trade, national or international standards (specify standard). Hole configuration according to individual requirements are also delivered (specify drill pattern and hole diameter, provide drawing or use sketch on last page).

N.B. Depths [C] is the same with or without flanges.

Code	[mm] min-max
R	50-500



Code for radius, put R before the dimension, e.g. R150

Flanges specifications

Flange code		Position	Thickness*, T	
Continuous welded	Spot welded		code	mm
F1	F11	Top & bottom front	T2	2
F2	F12	Left & right front	T3	3
F3	F13	All sides front	T5	5
F4	F14	Top & bottom back	T8	8
F5	F15	Left & right back	Width*, W	
F6	F16	All sides back	code	mm
F7	F17	Top & bottom, front & back	W30	30
F8	F18	Left & right, front & back	W50	50
F9	F19	All sides front & back	W60	60

Material: Aluminium and stainless steel in accordance with the frame material selected. * Other thickness or width on request.

Protection grid and mesh type specifications

Protection grid code	Position	Mesh width, S		Mesh type, wire diameter, d Ø [mm]			
		inch	mm	1.0	1.2	1.5	2.0
G1	Front	1/4 x 1/4	5 x 5	Q1			
G2	Back	1/4 x 1/4	6 x 6	Q2	X2		
		1/3 x 1/3	8 x 8	Q3	X3		
		1/2 x 1/2	10 x 10	Q4	X4		
		1/2 x 1/2	12 x 12	Q5		Y5	
		3/4 x 3/4	16 x 16	Q6	X6	Y6	
		3/4 x 3/4	20 x 20	Q7		Y7	Z7
		1 x 1	25 x 25			Y8	Z8

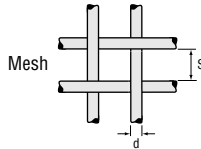

Material: Stainless steel 304 (AISI 304, DIN 1.4301). N.B. Protection grid is mainly used as trash screen on air inlets. Pressure drop over wire mesh is negligible. Aluminium grids can be delivered on request.

DF 4800

DF 4800 droplet separator is developed to suit a wide range of applications. The various outfit options cover the most typically occurring installation variations. However, tailor made droplet separators are frequently delivered based on customers' individual specifications.

Material certificates can be delivered for most materials upon request. Fractional efficiency curves for given face velocities are delivered on special request.

For hygienic-proof HVAC equipment DF 4800 droplet separator can be delivered in accordance with the standards VDI 6022, VDI 3803, DIN 1946 (specify H in order code).

DF 4800 is developed and produced by Munters Euroform GmbH, Germany.

Order information

DF 4800-X-X-X-X-X-X-X-X-X-X-X

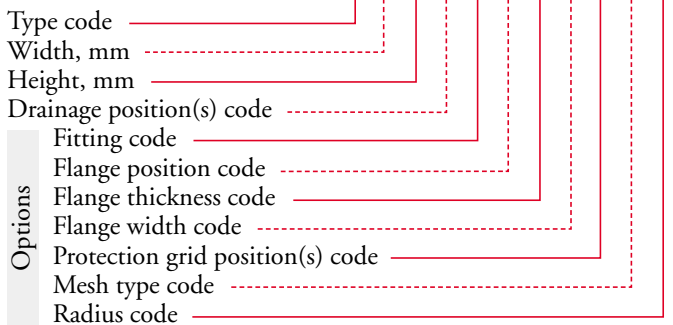

e.g., DF 4800-8a-1820-1200-P9-A5-F2-T2-W30-G2-Q4-R150

Examples of installation

1. The droplet separator is flanged onto a wall opening and the water drains vertically outside of the wall.
2. The droplet separator is flanged into a wall opening and the water drains controlled into an internal tray (not shown in the drawing)
3. The droplet separator is installed in an air duct and stands in between angled profiles that are connected to the air duct. The water drains through the bottom into a tray that is below the air duct.
4. Galvanic separation of carbon steel structure from the mist eliminator (made of stainless or aluminium).

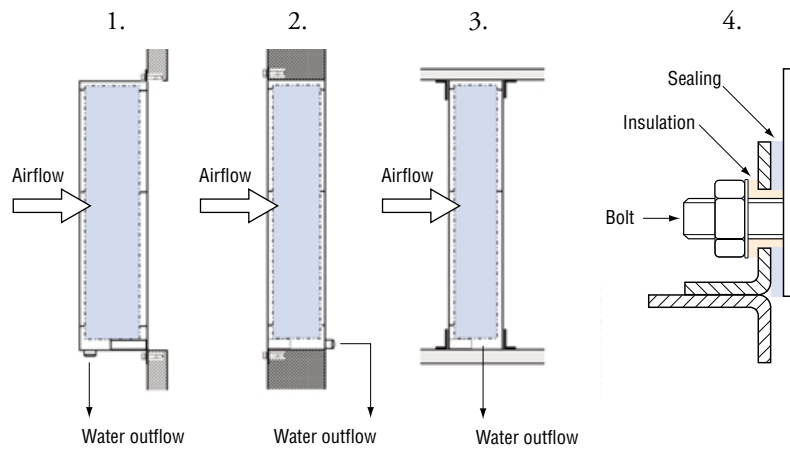

Drill pattern sketch

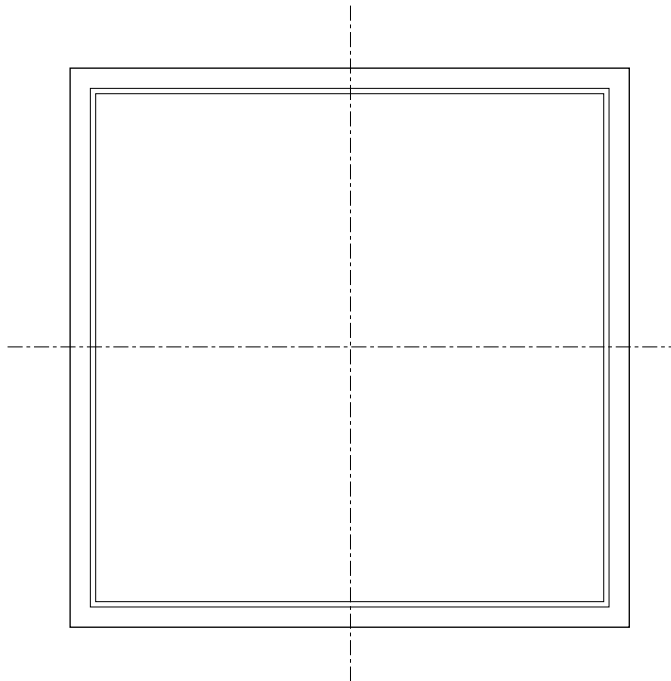

Munters Europe AB, HumiCool Division, Kung Hans Väg 8, P O Box 434, SE-191 24 Sollentuna, Sweden. Phone +46/(0)8/626 63 00, Fax +46/(0)8/754 56 66.
 Munters Euroform GmbH, Philipsstr.8, D-52068 Aachen, P O Box 101109, D-52011 Aachen, Germany. Phone +49/(0)241/89 00 0, Fax +49/(0)241/89 00 5199.
www.munters.com

Austria via sales organization in Germany Munters Euroform GmbH, Phone +49/(0)241/89 00 0, Fax +49/(0)241/89 00 5199, **Denmark** via sales organization in Sweden Munters Europe AB, Phone +46/(0)8/626 63 00, Fax +46/(0)8/754 56 66,
Finland Munters Oy, Phone +358/(0)9/83 86 0330, Fax +358/(0)9/83 86 0336, **France** Munters France S.A., Phone +33/(0)1/34 11 57 50, Fax +33/(0)1/34 11 57 51, **Germany** Munters Euroform GmbH, Phone +49/(0)241/89 00 0,
 Fax +49/(0)241/89 00 199, **Italy** Munters S.R.L., Phone +39/(0)2/488 6781, Fax +39/(0)2/488 1171, Munters euroemme S.p.A., Phone +39/(0)183/52 11, Fax +39/(0)183/521 333,
Kingdom of Saudi Arabia and Middle East Hawa Munters, c/o Hawa United Cooling Syst. Co. Ltd., Phone +966/(0)1/477 15 14, Fax +966/(0)1/476 09 36, **Norway** via sales organization in Sweden, Munters Europe AB,
 Phone +46/(0)8/626 63 00, Fax +46/(0)8/754 56 66, **South Africa & Sub-Sahara Countries** Munters (Pty) Ltd, Phone +27/(0)11/455 2550/1/2, Fax +27/(0)11/455 2553, **Spain** Munters Spain S.A., Phone +34/91/640 09 02,
 Fax +34/91/640 11 32, **Sweden** Munters Europe AB, Phone +46/(0)8/626 63 00, Fax +46/(0)8/754 56 66, **Switzerland** via sales organization in Germany, Munters Euroform GmbH, Phone +49/(0)241/89 00 0, Fax +49/(0)241/89 00 199,
United Kingdom Munters Ltd, Phone +44/(0)1480/442 340, Fax +44/(0)1480/411 332, **Export & Other countries** Munters Europe AB Phone +46/(0)8/626 63 00, Fax +46/(0)8/754 56 66,
Region Americas Munters Corporation, Phone +1/(0)978 241 1100, Fax +1/(0)978 241 1214, **Region Asia** Munters K.K., Phone +81/(0)3/5970 0021, Fax +81/(0)3/5970 3197