

PRODUCT INFORMATION

DMV- Wire Mesh Separator & Agglomerator

DMV

Wire mesh separator & agglomerator

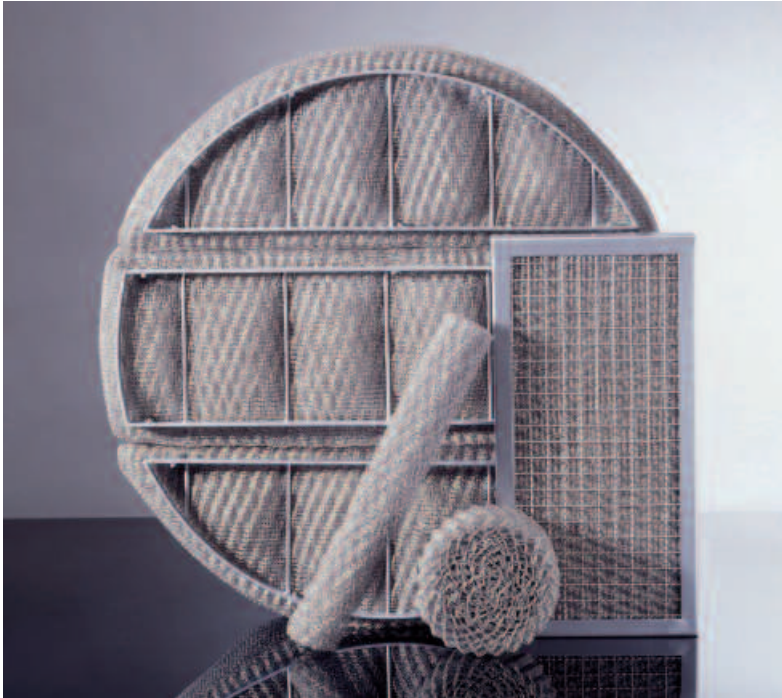

As Separator (DMV-S)

- Used in vertical gas flows at low to medium gas velocities
- Recommended for demisting service with a moderate liquid load on form of droplets
- Recommended for process conditions with very high turn down ratios (factor 4)
- High slug handling capacity
- Available in stainless steel, plastic or other materials

As Agglomerator (DMV-A)

- Used in horizontal gas flows at low to high gas velocities
- Recommended to serve as agglomerator of small droplets for vane type separators in process conditions with high velocity and turn down ratios (factor 4)

Munters DMV mesh type separators are specifically designed to separate small droplets from continuous vertical gas flows. They are comprised of a knitted mesh of stainless steel, plastic (or other materials upon request) contained between a stainless steel framework. They are typically used for vertical gas flows in order to serve specific separation task or to serve as an agglomerator for a vane type separator in a horizontal gas flow. This separation technology (wire mesh separation) especially addresses process conditions with very high turn down ratios (factor 4).

Munters DMV-series is well suited for a special range of liquid gas processing applications, particularly where the flow velocity is related to mass transfer.

Typical applications (as separator DMV-S)

- Vertical columns with mass transfer service
- Small diameter towers

Typical applications (as agglomerator DMV-A)

- Liquid sulphur removal
- Compressor protection
- Sulphuric acid plants
- LNG plants / Ammonia plants

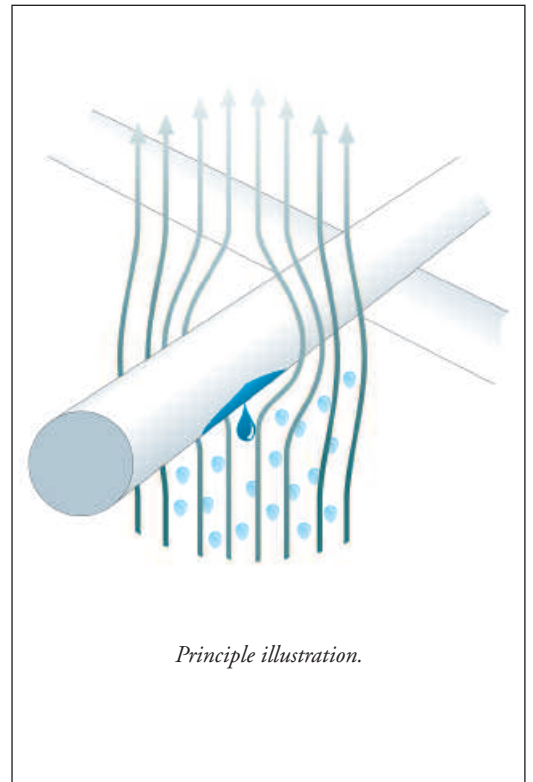

Principle illustration.

DMV-S for vertical flow services (as separator)

Liquid droplets entrained in a gas flow impinge on the strands that form the mesh. Smaller droplets flow round the strand and carry on through with the gas, while larger droplets coalesce and are dragged downwards by gravity for collection. This type of configuration may be encountered for example in pressurized systems such as natural gas applications where liquids with low surface tension are being transferred. Ideally the fluids should be relatively clean as this is not a gas cleaning technology.

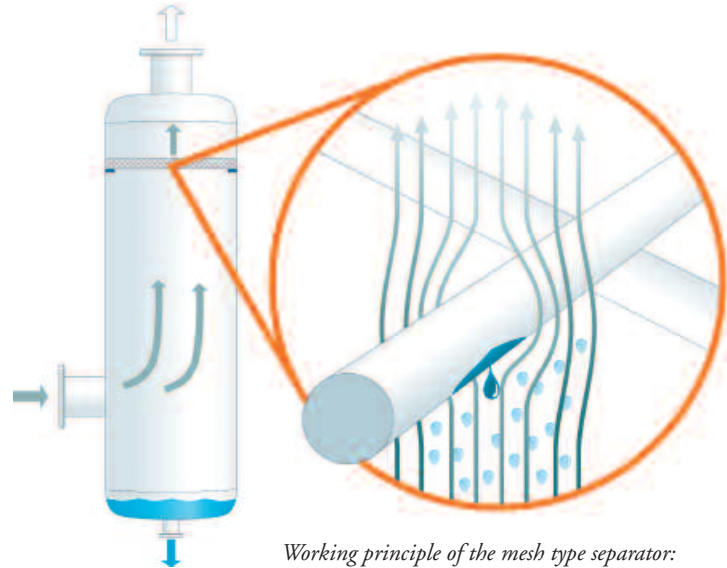

Working principle of the mesh type separator: impingement, coalescence and drain by gravity.

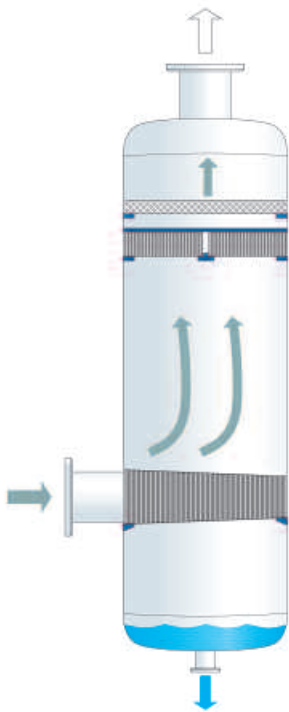

Wire mesh separator downstream of a Munters DV270 vane type separator.

Munters offers various types of wire mesh separators, specified by free volume, specific surface of the packing, wire thickness and height of packing.

Munters DMV-S mesh type separator can also be used downstream of a vane type separator in order to remove finest droplets under low velocity conditions (process conditions with high turndown ratios)

Product information

Material

Stainless steel 316Ti, 316L, special materials upon request

Design

Round shaped with diameters up to 5,000 mm (comes in segments)

Efficiency

DMV-S separators can be designed to remove droplets in the range of larger than 5 μm .

Munters DMV-S mesh type separators are recommended to be used for the following services

- Demisting of gas flows with low to moderate liquid loads
- Operations that require slug handling capacities
- Vertical vessels with space restrictions (small diameter towers)
- Glycol contactors
- Liquid recovery in vertical columns with mass transfer sections (lower gas velocity)

Type	Density [kg/m ³]	Surface area [m ² /m ³]	Porosity [%]	Application
DMV-S145	145	265	98.1	For standard conditions
DMV-S190	192	350	97.5	High separation efficiency
DMV-S430	432	1835	94.5	Separation of very small droplets

Other types upon special request.

DMV-A for horizontal flow services (as agglomerator)

Munters DVM-A mesh type agglomerator also serves as agglomerator in horizontal gas flows.

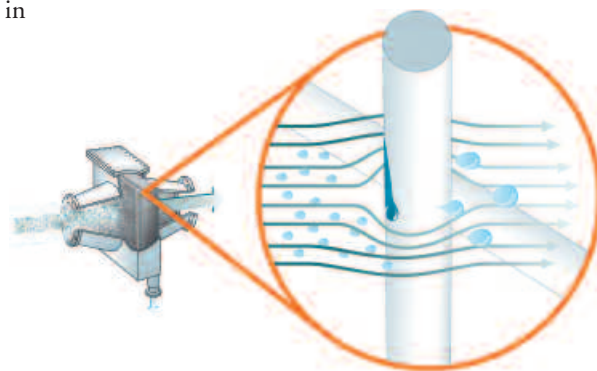
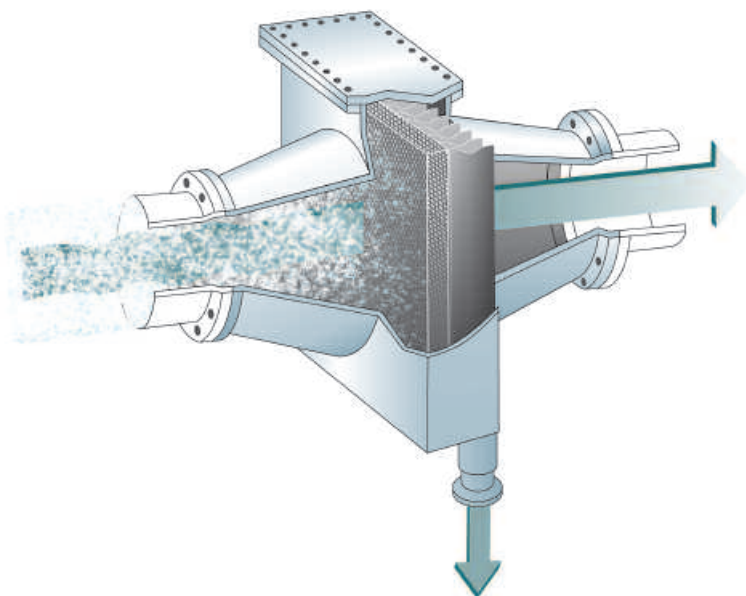

The DVM-A mesh type agglomerator forms larger droplets from small droplets. The larger diameter droplets are then retained in the gas flow that hits the subsequent vane type separator and the liquid is separated for recovery. These end up in a vane-type separator for complete removal.

Agglomeration of small droplets into larger; release of the larger droplets into the vane type separator.

Product information

Combinations of a DMV type agglomerator and a vane type separator have several **advantages**:

Rectangular shaped high system design gas velocities leading to smaller separator sizes (increasing throughput)

Constant removal efficiency in applications with high velocities and high turn down ratios

Assure very low liquid rest contents for ideal subsequent component protection and highest product recovery

Useful for liquid recovery systems with drop sizes around 3-5 microns

Applied in high liquid load – high efficiency applications (for 3 stage exhaust systems)

Material

Stainless steel 316Ti, 316L, special materials upon request

Design

Customized rectangular shape to meet the requirements

Agglomeration efficiency

The DMV-A agglomerator can, in combination with a vane type separator, remove droplets in the range of 2-3 μm .

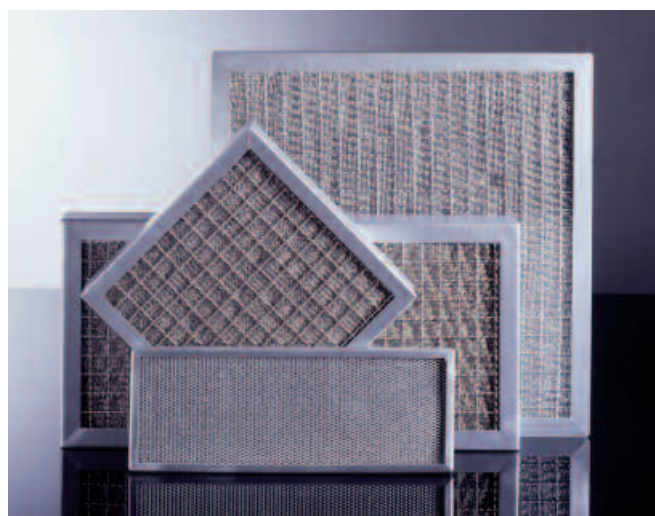

Typical applications for combination of DMV-A and DH vane type separators serve in the following applications:

- Liquid sulphur removal
- Compressor protection
- Sulphuric acid plants
- LNG plants / Ammonia plants

Example: Liquid sulphur recovery system in a Claus Plant

In sulphur recovery systems, such as by the Claus catalyst process (see illustration), liquid sulphur is obtained in various stages of the process. The elementary sulphur produced as well as sulphur components entrained from the Claus recovery system by the gas in the form of vapours or fine mist proportions (i.e. aerosols) are admitted to the sulphur separator via a catalyst with downstream process gas cooler. The liquid sulphur must be removed at a working temperature of 135–165 °C (which is above the solidification point).

Sulphur separators are built as special-purpose separator vessels which include a DMV-A mesh type agglomerator and a downstream DH vane type high capacity separator unit. In this vane type separator the fluid flow is split into individual streams, and the liquid is entrained by flow force effect into the area of the collecting traps from which it gravitates down as a liquid film.

Order information

Specific shapes and dimensions available upon request.
For more technical information, please contact your nearest Munters office.

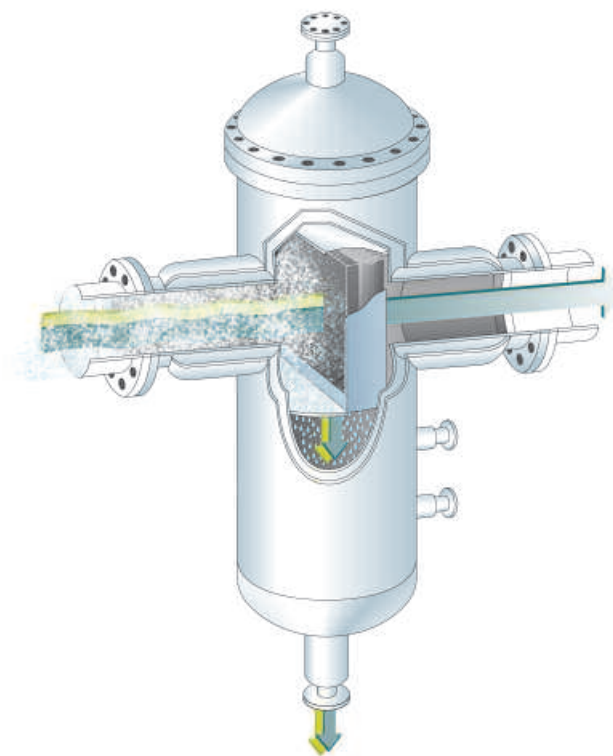

Munters GOH type 2 stage separator with Munters DMV-A mesh type agglomerator and DH5000 vane type separator.



Munters, HumiCool Division, Isafjordsgatan 1, P.O. Box 1150, SE-164 26 Kista, Sweden. Phone +46 8 626 63 00, Fax +46 8 754 56 66.

Munters Euroform GmbH, Philippsstrasse 8, P.O. Box 101109, DE-52011 Aachen, Germany. Phone +49 241 89 00 0, Fax +49 241 89 00 5199, mist-elimination@munters.com

Munters Corporation, 210 Sixth Street SE, P.O. Box 6428, 33911 Fort Myers FL, USA. Phone +1 239 936 1555, Fax +1 239 936 8858, usfmycs_me@americas.munters.com

www.munters.com

Australia Munters Pty Limited, Phone +61 2 6025 6422, **Austria** via Munters Euroform GmbH, **Brazil** Munters Brasil Industria e Comercio Ltda, Phone +55 41 3317 5050, **China** Munters Air Treatment Equipment (Beijing) Co. Ltd., Phone +86 10 80 481 121, **Denmark** via sales organization in Sweden, **Finland** Munters Oy, Phone +358 9 83 86 030, **France** Munters France S.A., Phone +33 1 34 11 57 50, **Germany** Munters Euroform GmbH, Phone +49 241 89 00 0, **India** via Munters Euroform GmbH, **Indonesia** Munters, Phone +62 21 9105 4467, **Italy** via Munters Euroform GmbH, **Japan** via Munters Euroform GmbH, **Kingdom of Saudi Arabia and Middle East** via Munters Euroform GmbH, **Korea** via Munters Euroform GmbH, **Mexico** Munters Mexico, Phone +52 818 262 54 00, **Norway** via sales organization in Sweden, **Russia** Munters Europe AB, Phone +7 812 448 5740, **South Africa and Sub-Sahara Countries** Munters (Pty) Ltd., Phone +27 11 997 2000, **Spain** via Munters Euroform GmbH, Office Barcelona, Phone +34 93 688 1017, **Sweden** Munters Europe AB, Phone +46 8 626 63 00, **Thailand** Munters Co. Ltd., Phone +66 2 645 2708 12, **United Kingdom** Munters Ltd., Phone +44 845 644 3980, **USA** Munters Corporation **Fort Myers**, Phone +1 239 936 1555, Munters Corporation **Export & Other countries** Munters Euroform GmbH, Phone +49 241 89 00 0.

Your closest distributor